

Recommended Tools:

Safety Glasses	Variable Speed Drill	Extension Cord	Pencil
Work Gloves	1/2" Hole Saw	Socket Wrench	Level
Stud Finder	1/8" Drill Bit	Hex Head Drivers	Tape Measure
Ladder	5/16" Drill Bit	Crescent Wrench	Chalk Line
Framing Square	3/8" Masonry Bit	Hammer	Caulk Gun

Before You Begin:

Thank you for choosing the Amerimax Newport Patio Cover Kit. Before you begin there are several things to note:

1. Please read all instructions carefully. Check the Bill of Materials for any missing parts and gather necessary tools. The paint finish can be damaged so place materials on a tarp or other material to prevent scratching.
2. You may be required to obtain a building permit for an attached structure from your local building authority. This product can be installed in a 10, 20, 25, 30, 40 or 60 psf (pounds per square foot) snow load and 90 mph wind speed zone. This product is listed under ICBO Evaluation Report 2621P. You may have to submit two copies of your plot plan and also a copy of the evaluation report to your local building authority for a building permit. Contact your local building authority for details on your area's wind and snow load. This structure is classified as a Patio Cover as defined in Appendix Chapter 31 in the 1997 Uniform Building Code. For specific construction details, allowable spans and other technical details refer to ICBO 2621P.
3. Note that this patio cover is not designed to carry additional loads such as hanging plants, swings, people, trellis or other objects. This patio cover may not be enclosed with mesh screening.

1. Install Ledger Board. (Not included) (see note under step 2)

Note: Use a 2"x8" (1.5"x7.5" true size) Douglas Fir #2 or better for ledger board. Do not use pressed board, OSB or particle board.

A. Select mounting area on wall. Snap a level chalk line along the wall to locate the bottom of the ledger board. Remember, for proper drainage, the panels must be installed at a minimum 1/2" slope per foot of projection.

B. Attach ledger board to the side of the house or ends of the roof rafters as marked by the chalkline. Fasten the ledger board to the wood framing using 1/4"x4" lag screws. Refer to Table A below to determine how many lag screws per stud are required. Studs are assumed to be 16" o/c.

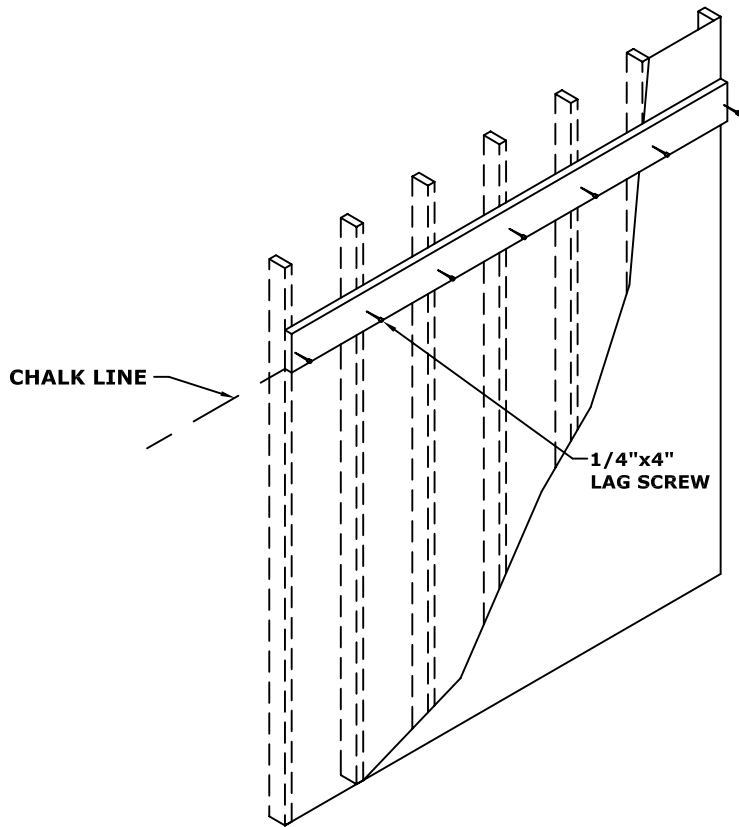

**Wall Attachment
w/ Ledger Board**

Table A: Lag Screws Required per Stud

Projection (ft)	Snow Load (psf)		
	10	20	30
8'	1	1	1
10'	1	1	1
12'	1	2	2
14'	1	2	2

**Wall Attachment
w/o Ledger Board**

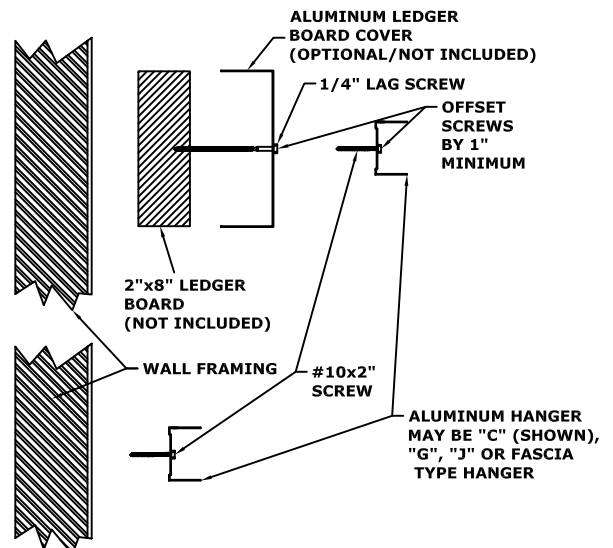

2. Awning Rail/Hanger

A. Snap a chalkline across the ledger board and use it as a guide for installing the hanger.

B. Place the hanger against the ledger board and along the chalkline, ensuring the hanger is level.

C. Place a #10x2" screw every 16" for 10 psf snow load (every 8" for 20 or 30 psf) along the hanger and snugly tighten down.

Note: For 10 psf snow load, a ledger board is not required.

3. Post Bracket Installation and Post Attachment

- A.** Posts should be plumb and bottom cut off if necessary to adjust the pitch of the panels for proper drainage and, at the same time, to adjust the header so that it is level from end to end. (Recommended roof pitch is 1/2" for each 1 foot of panel length)
- B.** With the posts cut to length, plumb them again and mark the slab for attachment. The anchors should be at least 4" away from an edge of the slab or expansion joint and 30" away from any crack. Two 3/8" holes should be drilled through the post brackets and corresponding holes 2.5" deep into the slab. Attach the brackets to the slab using the concrete anchors provided and hammering them into the concrete making sure not to damage the threads.
- C.** Next, fit each post onto its bracket and fasten with four #14x3/4" sheet metal or self drilling screw.

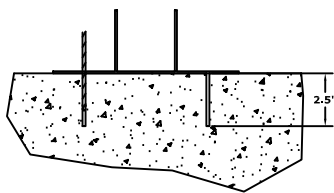
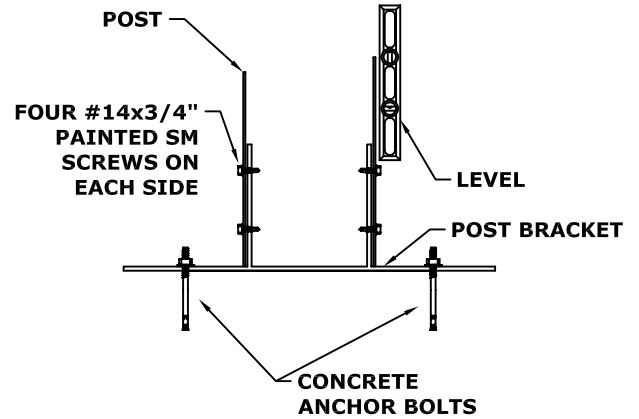
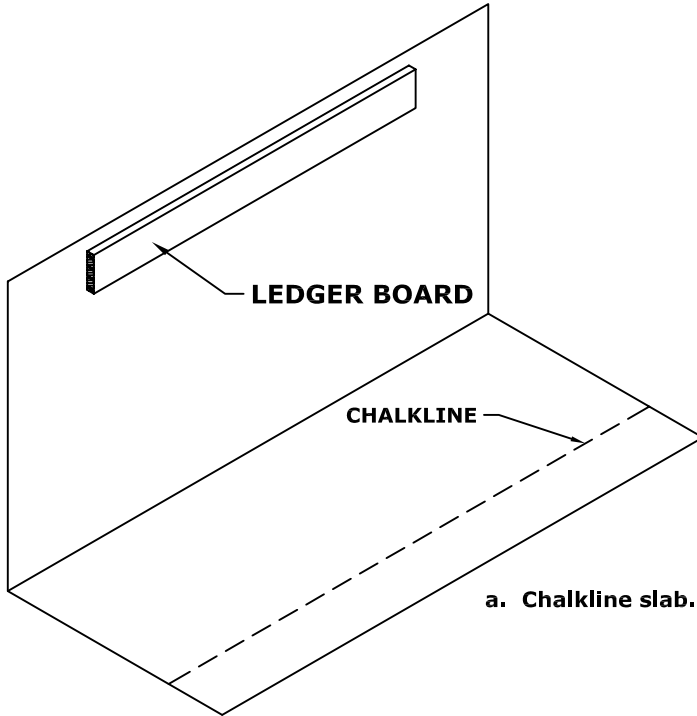

b. Drill 3/8" hole with the masonry bit at least 3" deep.

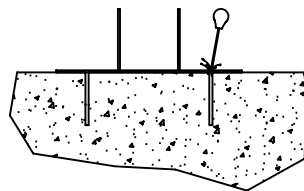

c. Clean hole by blowing out debris.

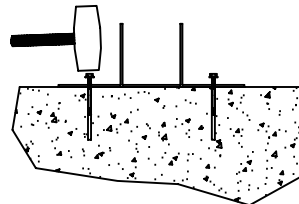

d. Drive the concrete anchor bolt far enough into hole so that at least six threads are below the surface. Do not damage threads.

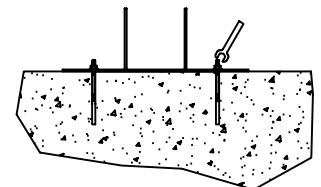

e. Tighten to 7 foot lbs with a torque wrench or 2 to 3 turns from the finger tight position to achieve the proper anchor setting.

4. Install Header

- A.** Set the Header on top of the posts. Make sure the seam side is up and lines up with the wall hanger on the ledger board.
- B.** Level the header.
- C.** Attach the post to the header using the bracket as shown

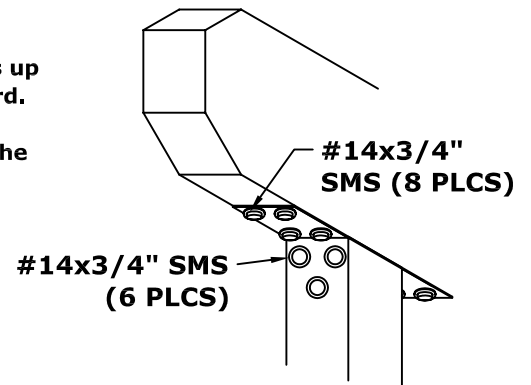
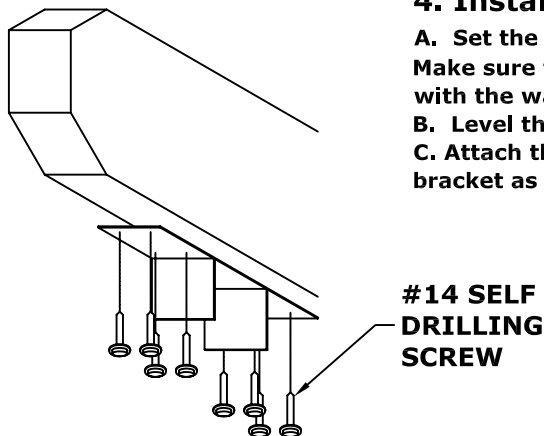

5. Install Sideplates on Posts

Note: Sideplates should be stuffed with foam.

- A. Place the sideplate so that it is centered on the post. Measure 12" from the bottom of the sideplate and drill a 5/8" hole through one side and the foam, making sure not to puncture the other side or dent the sideplate.
- B. Place a #14x3/4" SM screw through the sideplate into the post.
- C. Measure and mark up 24" on center. Drill a 5/8" hole.
- D. Use a level to make sure the sideplate is centered on the post and plumb.
- E. Place a #14x3/4" SM screw through the remaining holes.
- F. Drill four holes into the sideplate as done previously but for the header/sideplate attachment. (As shown)
- G. Place a #14x3/4" SM screw into the four holes.
- H. Place the 5/8" plugs into the holes.
- I. Repeat these steps on the opposite side and for all remaining posts.

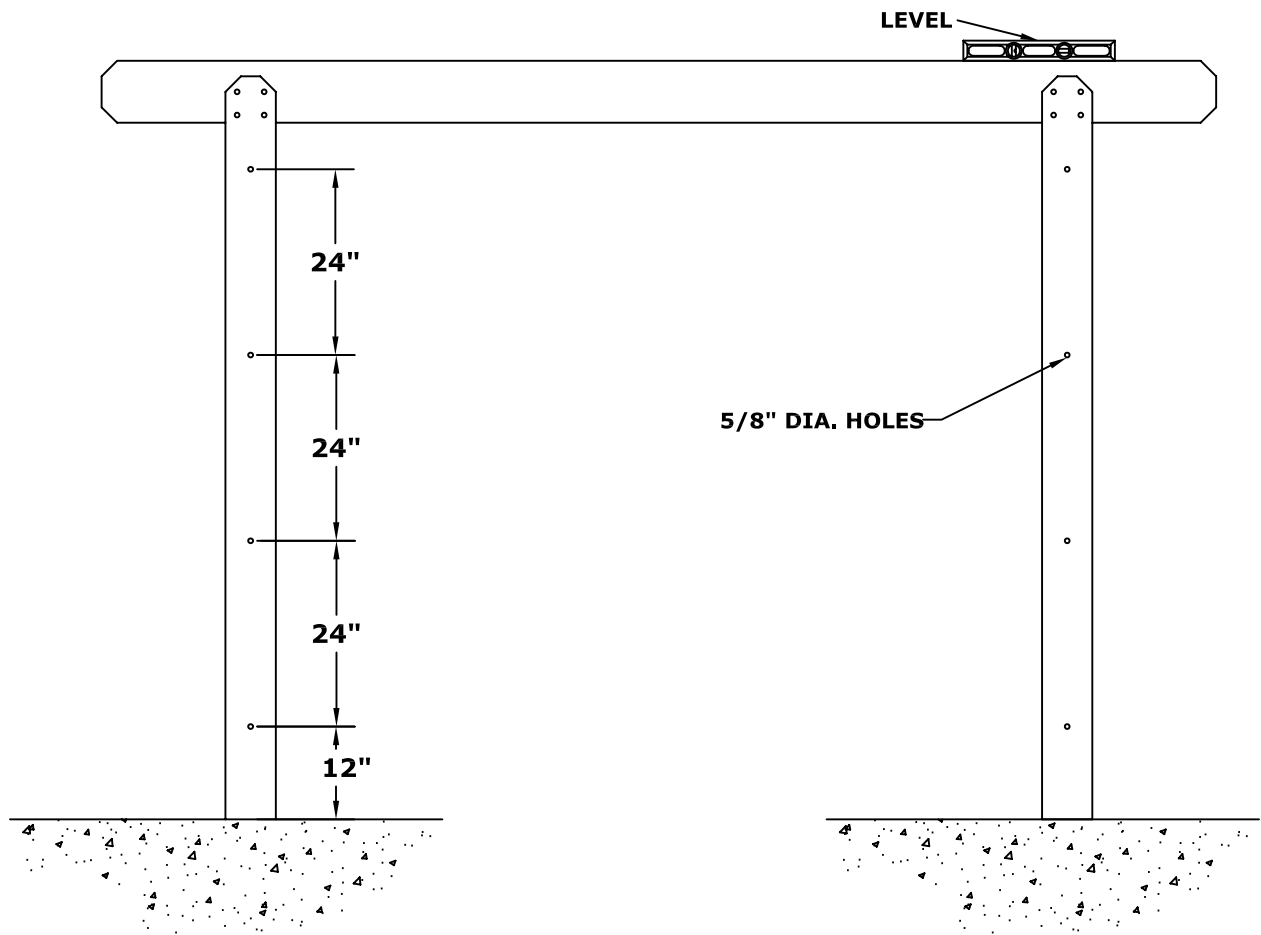
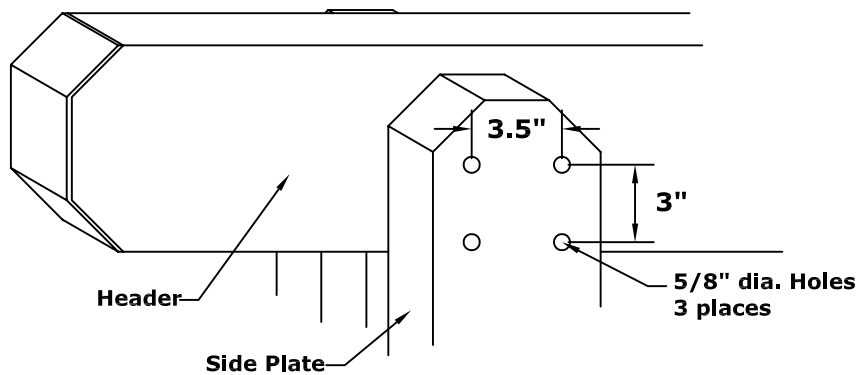

6. Install Roof Panels

Note: Install one panel between the hanger and header on each end of the patio using ONE #10x1/2" SM screws at each end of the panel. Check for squareness of the structure, shifting the header until square. Then permanently fasten one of the panels as shown. Additional panels will be installed from this end.

- A. Place one screw from above into the flat of the panel into the wall hanger. In addition, place one screw through the top of the hanger and into the mated interlock.
- B. Remove the last panel and properly install it into the adjacent panel.

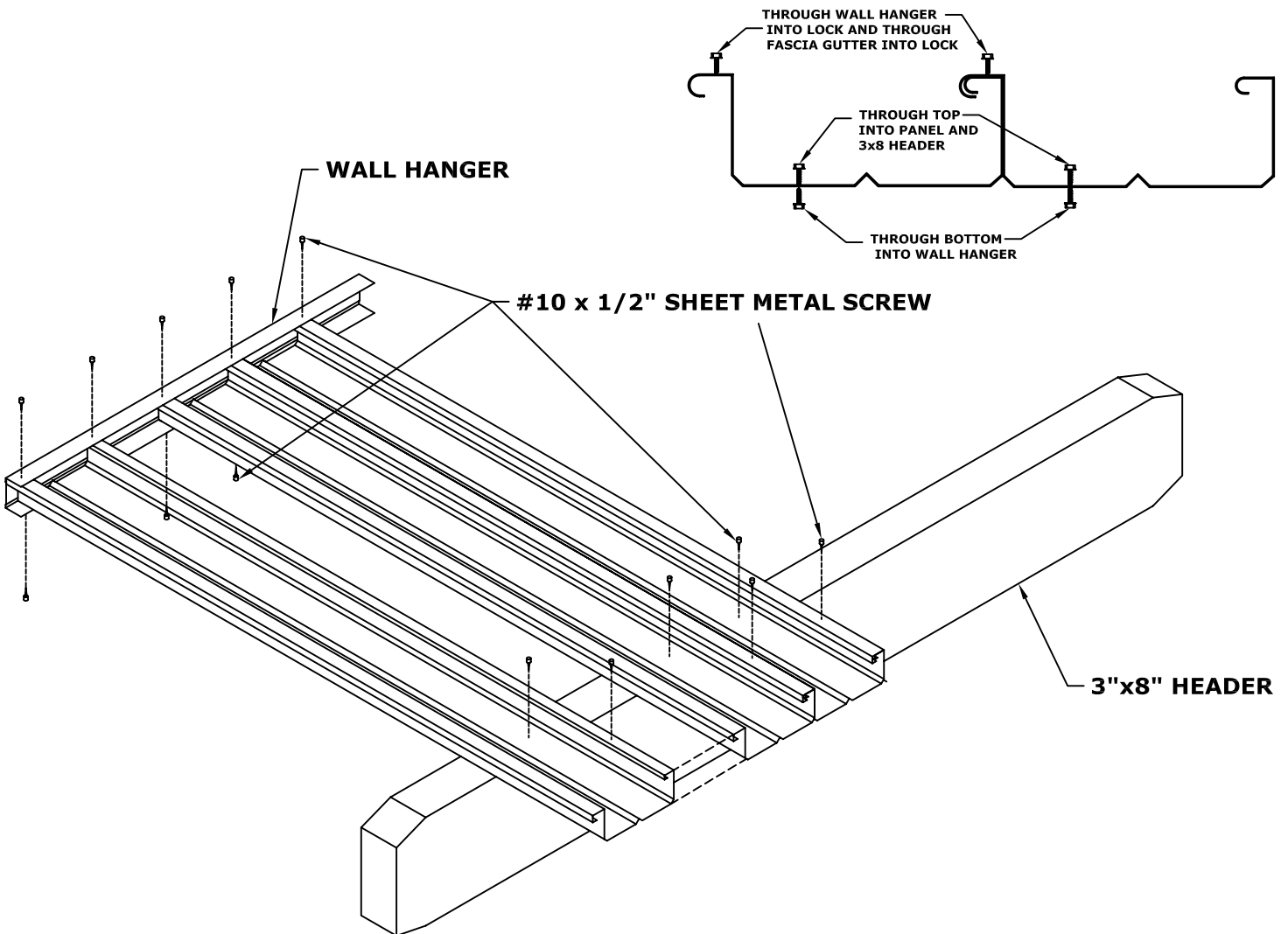

7. Gutter/Fascia Assembly

Note: This section is only necessary if the gutter fascia is provided in two or more sections.

- A. Apply a generous amount of caulk to the inside ends of the gutters to be spliced.
- B. Place the splice so that it is evenly centered between the two headers.
- C. Fasten the splice using six #14x 3/4" sheet metal screws.
- D. Place the second header over the splice and butt it squarely with the other section. Again, fasten six more screws into the back leg.

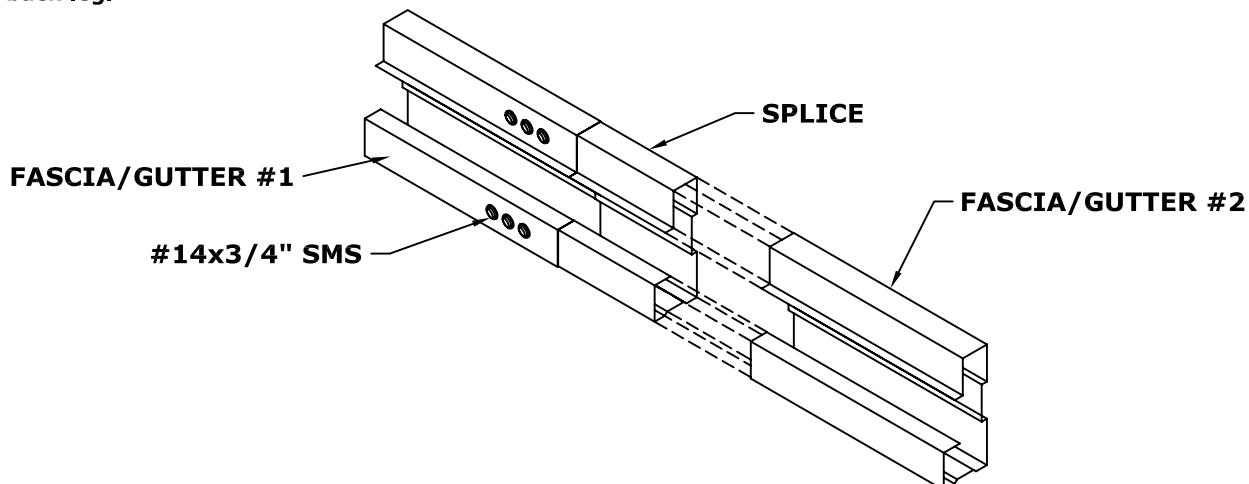

8. Mounting the Fascia/Gutter

Note: you may require assistance holding the Fascia/Gutter in place until properly secured.

- A. Place the Gutter/Fascia over the end of the panels. Place one #10x1/2" screw through every valley of the panel through the Gutter/Fascia.
- B. Place one #10x1/2" sheet metal screw through the lip of the Fascia/Gutter and through the interlock of the two panels. Some Fascia/Gutters do not have a lip but use small aluminum clips to attach to the Fascia/Gutter and then screw into the interlock.
- C. Repeat B along the entire length of Fascia/Gutter as shown.

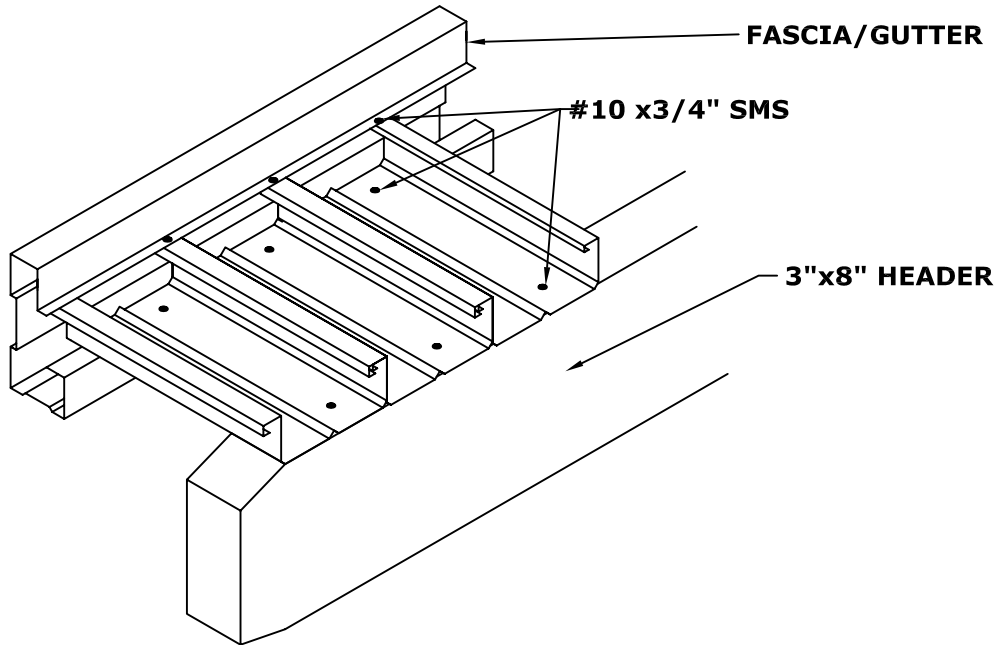

9. Install Side Fascia and Corners

- A. Place the side fascia in position as indicated. The opening of the side fascia should overlap the hanger at the house above and below and fit snugly against the end of the hanger. Cope cut the side fascia to meet the Fascia/Gutter.
- B. At the opposite end, the side fascia should overlap the Fascia/Gutter.
- C. Attach the side fascia with #8 x 1/2" sheet metal screws through the side fascia and gutter where they overlap. One on the top and two on the bottom. Place screws every 12" on center along the length of the top of the side fascia into the panel.
- D. Install side fascia to the opposite end of the patio in the same way.
- E. Install Corner Caps using four #8x 1/2" sheet metal screws. Place two through the side of the Fascia/Gutter and two through the side fascia.
- F. Repeat this step with opposite corner.

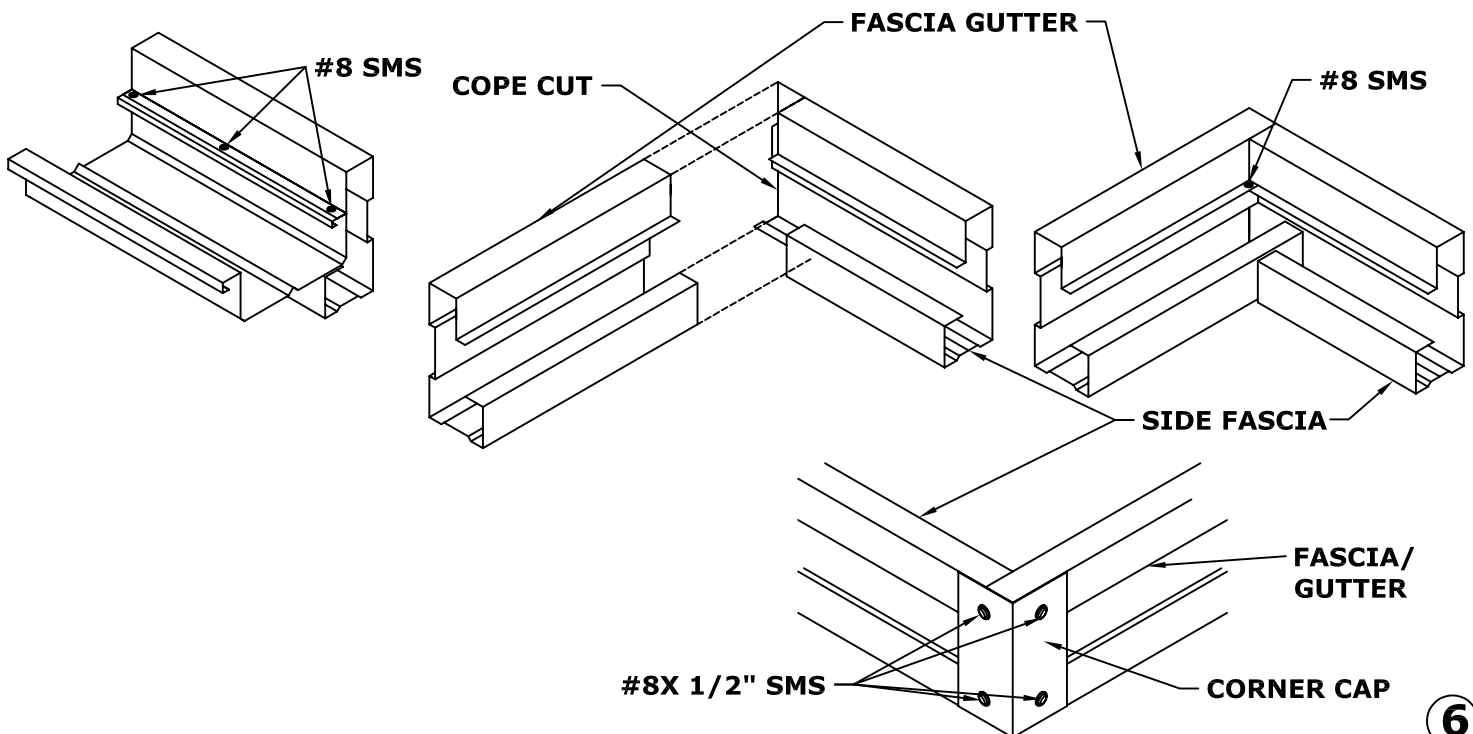

10. Install Aluminum Wood Trim

Note: This step is nonstructural and may be modified.

- Drill several 5/8" holes into one of the 2"x6.5" Rafters and attach to the side fascia as shown. This rafter should extend past the side fascia to the desired projection. Repeat for the other side.
- Cut on of the 2"x6.5" rafters so it fits snugly between the two side rafters. Attach to the Fascia Gutter.
- Attach Rafter Brackets at 24" o/c to the front of the front rafter. Use two #10 SMS.
- Attach Rafter Tails to the rafter brackets. Use four #10 SMS.

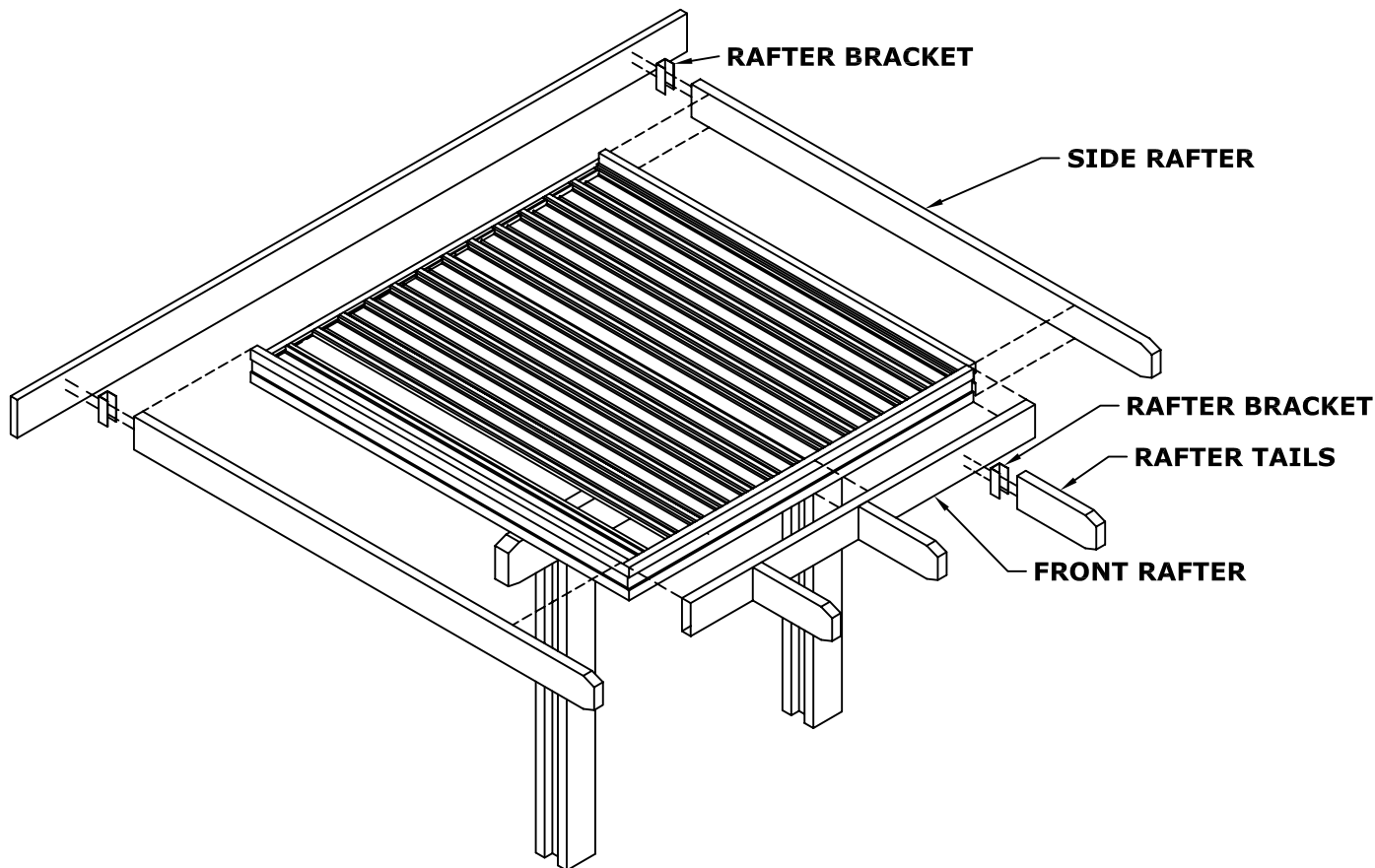

11. Install Rain Flashing

- Fasten rain flashing to the house wall or fascia board directly using #10 screws every 6".
- Fasten flashing to patio roof using #8x1/2" sheet metal screws at the roof panels interlock.
- Overlap lengths of flashing at least 1" and fasten through to panel interlock.
- Caulk generously all along the attachment to house.

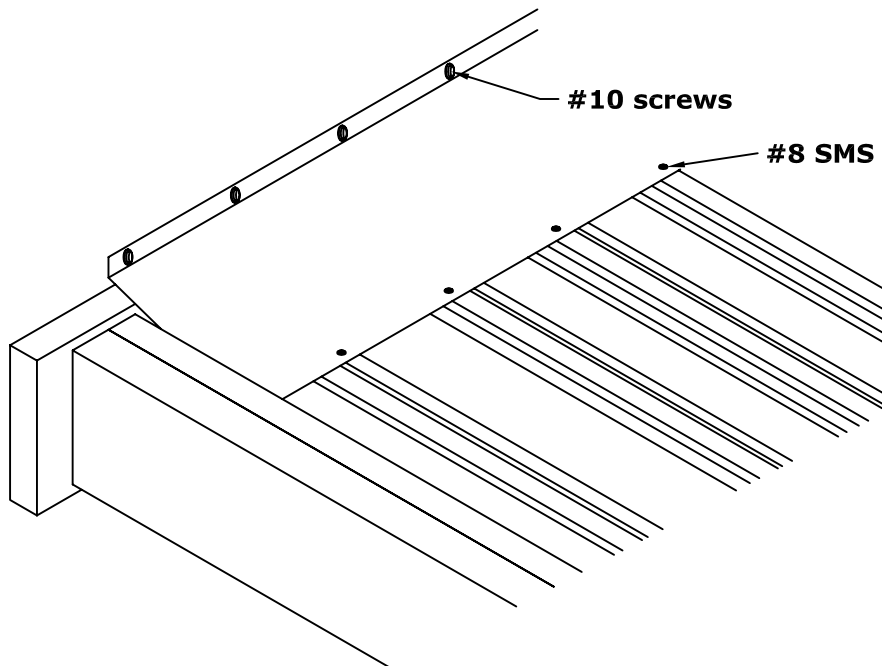

12. Install Downspouts

- Cut two 1" diameter holes in the bottom of the Gutter Fascia. This should be close to an end post.
- Place the downspout flange over the hole and fasten with #8x1/2" sheet metal screws.
- Insert the downspout elbow into one end of the downspout tube and fasten from the sides with #8x1/2" sheet metal screws.
- Hold the downspout assembly in place to check for proper length and cut as required.
- Slip the upper end of the downspout assembly over the downspout flange and fasten from the two sides with #8x1/2" sheet metal screws.
- Attach the downspout tube to the post with the strap. Fasten on two sides with #8 SMS.

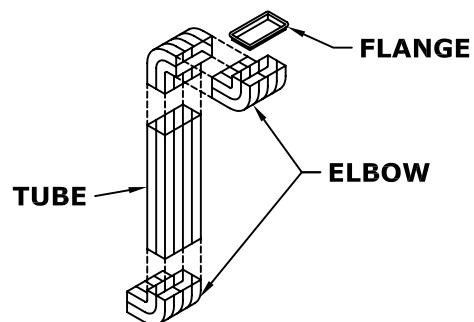

BILL OF MATERIALS

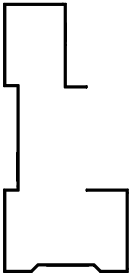

FASCIA/GUTTER

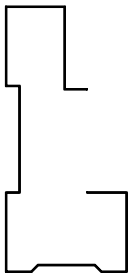

SIDE FASCIA/SPLICE

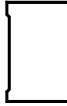

RF WALL HANGER



2.5"X6" FLAT PANEL

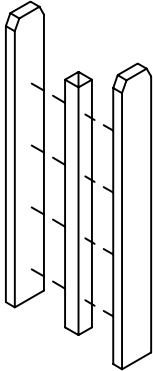

POST ASSEMBLY

- GUTTER/FASCIA
- SIDE FASCIA
- FASCIA SPLICE (IF REQUIRED)
- ROLL FORMED HANGER
- 6" ROLL FORMED PANEL
- 3"X3" ALUMINUM POST
- 2"X6.5" SIDEPLATES (FOAM INSERTS)
- 2"X6.5" SIDE TRIM RAFTERS
- 2"X6.5" FRONT TRIM RAFTER
- 2"X6.5" RAFTER TAILS
- 3"X8" ALUMINUM HEADER
- RAIN FLASHING
- FLANGED U POST BRACKET
- RAFTER BRACKETS
- 1/4"X5" LAG SCREW
- 3/8"X3.5" SS HILTI KWIK BOLT II
- #14X3/4" SELF DRILLING SCREW
- #10X1/2" SHEET METAL SCREW
- 10X2" SHEET METAL SCREW
- #8X1/2" SHEET METAL SCREW

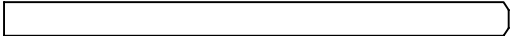

2"X6.5" TRIM SIDE RAFTER



3"X8" HEADER

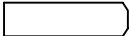

2"X6.5" RAFTER TAIL



2"X6.5" TRIM FRONT RAFTER

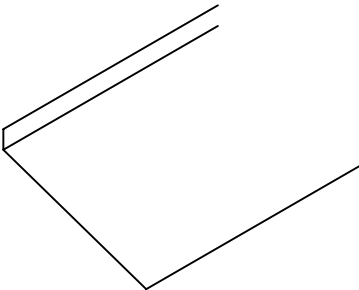

RAIN FLASHING

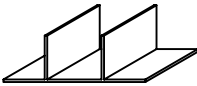

FLANGED "U" BRACKET

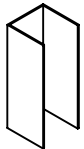

RAFTER BRACKET



LEDGER COVER



1/4"x5" LAG SCREW

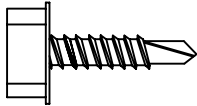

#14X3/4" SDS



#10x1" SHEET METAL SCREW



#10x1/2" SMS

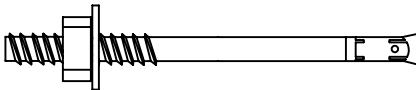

3/8"X3.5" SS HILTI KWIK BOLT II